



LONGITUDINAL EXTENSOMETER "Clip-On" Model MFA 20

The MFA 20 extensometer is suitable for determining yield strength and uniform strain for test specimens larger than 4mm in diameter and 15mm in width.

The measurement accuracy corresponds to accuracy class 0.5 according to EN ISO 9513.

APPLICABLE STANDARDS

EN ISO 9513.

AREA OF APPLICATION

The extensometer MFA 20 is suitable for determining the yield point and uniform deformation for test samples above 4 mm diameter and 15 mm width. The measurement accuracy corresponds to the accuracy class 0.5 of the EN ISO 9513.

Because of its extremely robust design the instrument is suited for heavy duty service such as testing of construction steel and rough samples with scale etc.

The gauge length may be adjusted very quickly and precisely from 50 to 200 mm in 10 (5) mm-steps by shifting the lower knife edge holder.

The clamping may be made without any problems with one hand. The parallel positioning of the MFA 20 in respect to the axis of round samples is guaranteed by centering two double knife edges (see top view of the sketch).



DESIGN AND FUNCTION

The MFA 20 consists of two casing halves which move parallel and easily towards each other on play-free guidance bars. The upper casing overlaps the lower casing for the total extension so that the parallel guide and the measuring system are protected from damage and dust. A measuring spring with a temperature compensated full bridge strain gauge serves as the measuring system for the MFA 20. The knife edge holders and the clamping device can be positioned easily by loosening just one knurled screw. Alignment pins fix them in their exact position.

To achieve a symmetrical position of the counter rollers with respect to the knife edges, the counter roller fixture can be turned and the clamping device shifted in three steps. The initial gauge length can be adjusted up to 140 mm with the upper extension arm and up to 200 mm with both the upper and lower extension arms in steps of 10 mm. Even intermediate lengths like e.g. 55 to 195 mm may be obtained by additional shifting of the upper and lower knife edges (see diagram). The clamping device is compatible to that of the MFA 2/05.

Opening width and clamping force are continually adjustable. For initial gauge lengths, greater than 100 mm the holder which belongs to the extension arm and has the greater distance between the counter rollers must be used. The casing is made of a high strength aluminum alloy and has a long lasting and scratch-resistant hard anodized surface. For the small parts argent tan and stainless steel are used. The round knife edges can be utilized along the entire perimeter by rotating them. Thereby a longer lifetime is achieved.

FUNCIONAMIENTO

For clamping the MFA 20 open the clamping device with thumb and fore finger. While mounting, care has to be taken that the lower knife edges are placed on the sample first. The measurement can be started then. No unlocking or adjustments have to be made to operate the MFA 20.

RECOMENDACION

If the "LO" has to be changed very often to intermediate lengths an additional set of knife edge holders may be useful and time-saving. The calibration instruments KMF 1 and KMF 01 are suitable for linearity checks.

Delivery scope

- * 1 MFA 20, Lo from 50mm to 100mm with 5 m cable
- * 1 MFA 20 clamping device with cylindrical counter rollers
- * 1 Knife edge holder (upper)
- * 1 Knife edge holder (lower)
- * 2 Spare fastening screws M3x8 T10
- * 1 TORX screwdriver, T10
- * 1 Test Specification Sheet
- * 1 Storage case

Spare parts and accessories

- ✓ Special clamping device for samples of 60mm width and 60mm thickness
- ✓ Extension arm (upper) up to $L_0 = 140\text{mm}^{**}$ and fixture with larger counter roller distance
- ✓ Extension arm (lower) up to $L_0 = 160\text{mm}^{**}$ and fixture with larger counter roller distance
- ✓ Spare fastening screw M3x8 T10 for knife edge and extension arm
- ✓ Spare knife edge, $\varnothing 9\text{mm}$
- ✓ Knife edge holder (upper) with knife edges
- ✓ Knife edge holder (lower) with knife edges

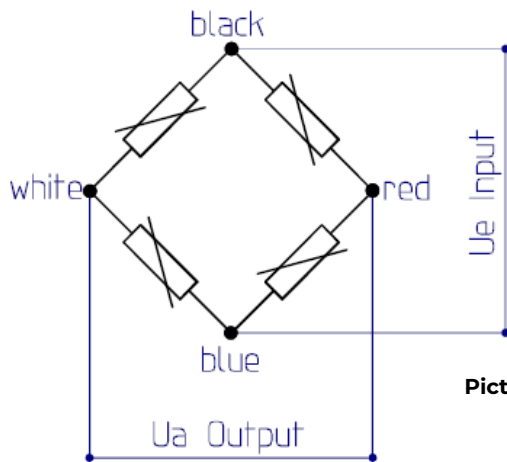

Picture 1: Connection diagram:

* Depending on version

** With both extension arms a "L0" of up to 200mm can be achieved

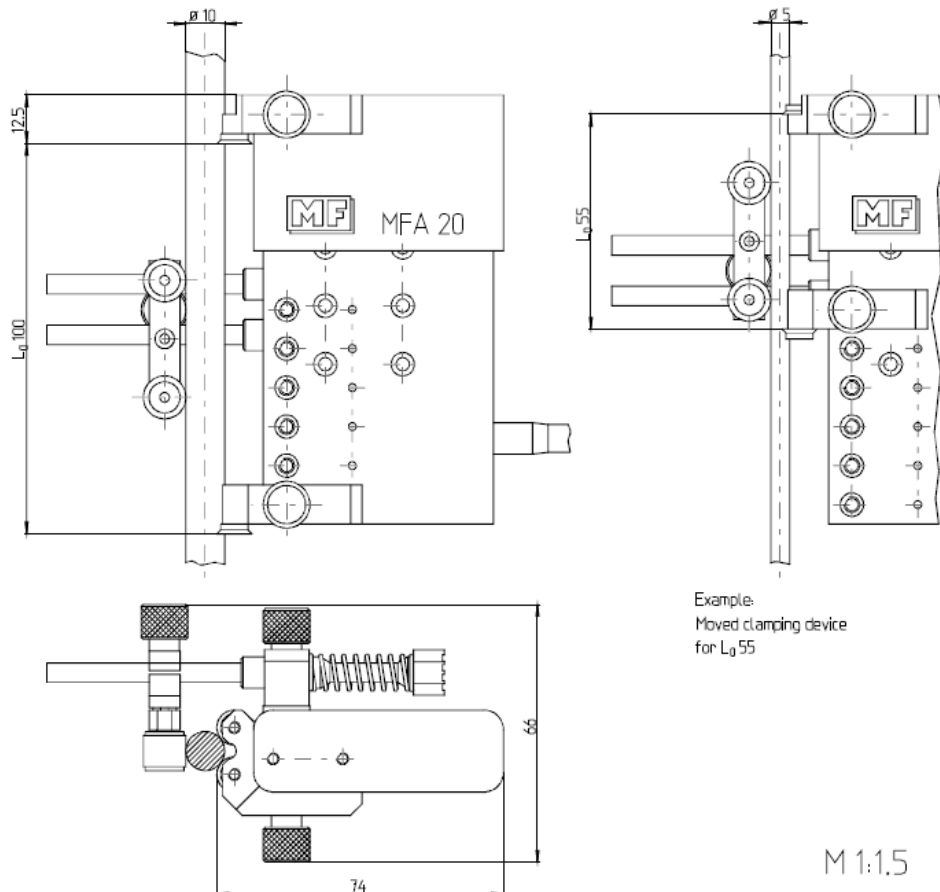

TECHNICAL DATA OF THE MFA 20 EXTENSOMETER

Accuracy class EN ISO 9513	0.5
Measuring principle	Strain gauge full bridge
Travel for tensile test	+20 mm
Measuring path tolerance	50 µm
Measuring path tolerance	0,25%
Linearity error including hysteresis	0.2 %
Indication error (rel.) *	0.5 %
Indication error *	1.5 µm
Error in gauge length	0,5 %
Activating force	150 cN
Sensitivity	2 mV/V
Rated resistance of bridge	350 Ohm
Standard gauge length (Lo)	50 to 100 mm (steps of 10 (5) mm)
Option gauge length (Lo)	From 40 mm
Accessory gauge length (Lo)	Up to 200mm (steps of 10 (5) mm)
Weight	ca. 480 g

* The larger value is permissible

Adjustable for sample cross sections

Round	Ø 4 to 30 mm
Flat	15 x 1 to 30 x 30 mm
With special clamping device	Ø 4 to 60 mm
With special clamping device	60 mm thickness and 60 mm width
Flat with adapter	0 to 60 mm thickness and 60 mm width
Cable length	5 m

Strain gauge

Sensitivity	1 mV / V
Rated resistance of bridge	350 Ohm
Voltage input	5 V
CLK frequency	5 kHz